

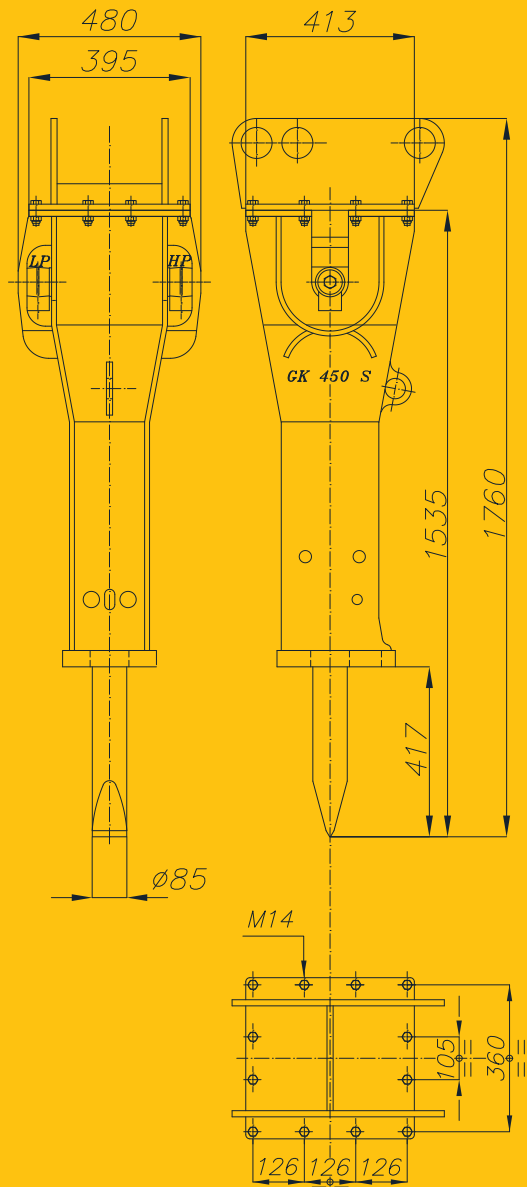

Italdem®

GK 450 S-NG HYDRAULIC BREAKER



OPERATING WEIGHT	450 KG (992 LB)
TOOL DIAMETER	85 MM (3.35 IN)
OIL FLOW	75÷100 L/MIN
WORKING PRESSURE	105÷115 BAR (1523÷1668 PSI)
RELIEF VALVE	150 BAR (2175 PSI)
MAX. BACKPRESSURE	12 BAR (174 PSI)
BLOW ENERGY	1050 JOULE
REQUIRED POWER	18.8 KW (25.5 HP)
IMPACT RATE	650÷900
CARRIER WEIGHT	7÷11 T (15432÷24251 LB)
MAX. NOISE LEVEL (SILENCED VERSION)	90 DB-A
INNER DIAMETER HP LINE	20 MM (0.79 IN)
INNER DIAMETER LP LINE	30 MM (1.18 IN)